

JAW TYPE ELASTOMERIC COUPLINGS



SECTION F3

L-JAW



Straight Jaw

- 100% interchangeable with industry standard
- 4 Insert materials available
- Large selection of sizes

C-JAW

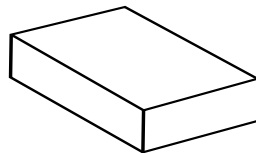

Straight Jaw

- Uses individual cushions
- For higher torque loads
- Cushions easily replaced

JAW COUPLING SELECTION

Determine the Prime Mover Classification

Prime Mover	Class
• Electric Motors (Standard duty), Hydraulic Motors, Turbines	A
• Gasoline or Steam Engines (4 or more cylinders)	B
• Diesel or Gas Engines, High Torque Electric Motors	C

Determine the Load Characteristics and the Service Factor

Typical Applications	Load	Characteristics	Prime Mover Class		
			A	B	C
Agitators (pure liquids), Blowers (centrifugal, Can and Bottle Filling Machines, Conveyors - uniformly loaded or fed (belt, chain, screw), Fans (centrifugal), Generators (uniform load), Pumps (centrifugal), Screens (air washing, water), Stokers (uniform load), Woodworking Machines (planers, routers, saws)	Uniform	Even loads - no shock - non reversing - infrequent starts (up to 10 per hour) - low starting torques — Up to 8 hours per day — Over 8 hours per day	1.0 1.5	1.5 2.0	2.0 2.5
Beaters, Blowers (lobe, vane), Compressors (centrifugal, rotary), Conveyors - non uniformly loaded or fed (belt, bucket, chain, screw), Dredge Pumps, Fans (forced draft, propeller), Kilns, Paper Mills (calendars, converting machines, conveyors, dryers, mixers, winders), Printing Presses, Pumps (gear, rotary), Shredders, Textile Machinery (dryers, dyers)	Moderate shock	Uneven loads - moderate shock Infrequent reversing-moderate torques — Up to 8 hours per day — Over 8 hours per day	1.5 2.0	2.0 2.5	2.5 3.0
Cranes (bridge, hoist, trolley), Fans (cooling tower), Generators (welding), Hammer Mills, Mills (ball, pebble, rolling, tube, tumbling), Pumps (oil well), Wire Drawing Machines	Heavy shock	Uneven loads - heavy shock - frequent starts and stops - high starting torques - high inertia peak loads — Up to 8 hours per day — Over 8 hours per day	2.0 2.5	2.5 3.0	3.0 3.5

Note: The above applications depict the generally accepted conditions encountered in industry. Conditions subject to extreme temperatures, abrasive dusts, corrosive liquids and dusts. Excessively high starting torques, etc., must be considered as extra heavy shock loads. These conditions will increase service factors. Consult factory for these selections.

Calculate Design Horsepower or Design Torque

- If Prime Mover is a 1200, 1800, or 3600 rpm motor.
Design Hp = Prime Mover HP x Service Factor
Go to page F3—3 and reference the corresponding motor rpm column.
- If Prime Mover is not one of the three speeds listed above.
Design Hp @ 100 rpm = (Prime Mover Hp x Service Factor x 100) / Coupling RPM
Go to page F3—3 and reference HP @ 100 RPM column.
- If Using Prime Mover Torque
Design Torque = Prime Mover Torque x Service Factor
Go to page F3—3 and reference Torque column.

Jaw Couplings are sold by component

Below is an ordering example for each Jaw style coupling.
All listed components must be ordered to receive a complete coupling.

Components	L-JAW		C-JAW	
	Product No.	Description	Product No.	Description
Driver Hub	L09958	L099 x 5/8	C280178	C280 x 1-7/8
Driven Hub	L09912NK no keyseat	L099 x 1/2	C280158	C280 x 1-5/8
Insert	L099N	L099 Buna-N	C280N (contains 6 cushions)	C280 Buna-N
Cover	none	none	C280CH w/ hardware	C280 Cover

TORQUE - HORSEPOWER RATINGS



L-JAW TYPE

PRODUCT NO.	MAX BORE	MAX RPM	BUNA-N SPIDER (N)					HYTREL SPIDER (H)					
			TORQUE IN. LBS	HP PER 100 RPM	HP/SPEEDS (RPM)			TORQUE IN. LBS.	HP PER 100 RPM	HP/SPEED (RPM)			
					1200	1800	3600			1200	1800	3600	
L035	3/8	31000	3.5	0.006	0.07	0.10	0.20						
L050	5/8	18000	26.3	0.042	0.50	0.75	1.50	50.0	0.079	0.95	1.43	2.86	
L070	3/4	14000	43.2	0.069	0.82	1.23	2.47	114	0.181	2.17	3.26	6.51	
L075	7/8	11000	90.0	0.143	1.71	2.57	5.14	227	0.360	4.32	6.48	12.97	
L090	1	9000	144.0	0.228	2.74	4.11	8.23	401	0.636	7.64	11.45	22.91	
1. L095	1-1/8	9000	194.0	0.308	3.69	5.54	11.08	561	0.890	10.68	16.02	32.04	
L099	1-3/16	7000	318.0	0.505	6.05	9.08	18.16	792	1.257	15.08	22.62	45.24	
2. L100	1-7/16	7000	417.0	0.662	7.94	11.91	23.82	1134	1.799	21.59	32.39	64.77	
L110	1-5/8	5000	792.0	1.257	15.08	22.62	45.24	2268	3.599	43.18	64.77	129.55	
L150	1-7/8	5000	1240.0	1.967	23.61	35.41	70.83	3708	5.883	70.60	105.90	211.80	
L190	2-1/8	5000	1726.0	2.739	32.86	49.29	98.59	4680	7.426	89.11	133.66	267.32	
L225	2-5/8	4600	2340.0	3.713	44.55	66.83	133.66	6228	9.882	118.58	177.87	355.74	
L276	2-7/8	4200	4716.0	7.483	89.79	134.69	269.38						

* BRONZE INSERTS HAVE SAME RATING AS HYTREL INSERTS.

WARNING: DO NOT USE BRONZE INSERT OVER 250 RPM.

* URETHANE INSERTS RATINGS MULTIPLY BUNA-N INSERT BY 1.5.

1. USES L090 SPIDERS 2. USES L099 SPIDERS

C-JAW TYPE

PRODUCT NO.	MAX BORE	MAX RPM	BUNA-N CUSHION SET (N)				
			TORQUE IN. LBS	HP PER 100 RPM	HP SPEEDS (RPM)		
					1200	1800	3600
C226	2-1/2	4800	2988.0	4.700	56.40	84.60	169.20
C276	2-7/8	4200	4716.0	7.500	90.00	135.00	270.00
C280	3	3500	7560.0	12.000	144.00	216.00	432.00
C285	4	3200	9182.0	14.600	175.20	262.80	525.60
C295	3-1/2	2300	11340.0	18.000	216.00	324.00	648.00
C2955	4	2300	18900.0	30.000	360.00	540.00	1080.00

SPIDER CHARACTERISTICS

CHARACTERISTICS	BUNA-N (N)	URETHANE (U)	HYTREL (H)	BRONZE (B)	
OIL RESISTANCE	GOOD	GOOD	EXCELLENT	EXCELLENT	
CHEMICAL RESISTANCE	POOR	GOOD	EXCELLENT	EXCELLENT	
FLEXIBILITY	EXCELLENT	GOOD	FAIR	POOR	
TEMPERATURE RANGE	F C	-40 TO +212 -40 TO +100	-30 TO +160 -35 TO +71	-60 TO +250 -51 TO +121	-40 TO +450 -40 TO +232
TORSIONAL STIFFNESS	FULL SOFT	MEDIUM SOFT	HARD	HARD	
AVERAGE HARDNESS (SHORE NUMBER)	80A	90A	55D	—	
MAX. MISALIGNMENT					
• ANGULAR	1°	1°	1/2°	1/2°	
• PARALLEL	.015"	.015"	.015"	.010"	
AVAILABILITY	L-JAW C-JAW	X X	X X	X X	
COLOR	BLACK	BLUE	WHITE	BRONZE	

TO ORDER SPIDER OR CUSHION SET SPECIFY THE COUPLING SIZE WITH THE MATERIAL SUFFIX.

EXAMPLE:
L150H =
HYTREL SPIDER FOR
L150 COUPLING



STOCK BORES

TB Wood's

STOCK L-JAW INCH HUBS

BORE (IN.)	PRODUCT NO.	L035	L050	L070	L075	L090	L095	L099	L100	L110	L150	L190	L225	L276
1/8	18	0												
3/16	3/16	0												
1/4	14	X	X	X	X	X								
5/16	5/16	0	0	X	0	X								
3/8	38	X	X	X	X	X								
7/16	7/16		X	X	X	X	X	X	X					
1/2	12		X	X	X	X	X	X	X					
9/16	9/16		1	1	X	1	1	1	X					
5/8	58		X	X	1	1	1	1	1	X	X			
11/16	11/16			1	1	1	1	1	1					
3/4	34			1	1	X	1	1	1	1	1	X	X	
7/8	78				1	1	1	1	1	1	1	1	1	0
15/16	15/16					1	1	1	1	1	1	1	1	
1	1					1	1	1	1	1	1	1	1	
1 1/16	1116						1		1	1	1		1	
1 1/8	118						1	1	1	1	1	1	1	1
1 3/16	1316							1	1	1	1	1	1	
1 1/4	114								1	1	1	1	1	1
1 5/16	1516								1	1				
1 3/8	138								1	1	1	1	1	1
1 7/16	1716								1	1	1	1	1	
1 1/2	112									1	1	1	1	
1 9/16	1916									1	1		1	
1 5/8	158									1	1	1	1	
1 11/16	11116										1	1	1	
1 3/4	134										1	1	1	1
1 13/16	11316										1			
1 7/8	178										1	1	1	
1 15/16	11516											1	1	
2	2											1	1	1
2 1/16	2116													
2 1/8	218											1	1	1
2 3/16	2316												1	
2 1/4	214												1	1
2 3/8	238												1	
2 1/2	212												1	1
2 5/8	258												1	
2 7/8	278													1

0 NO KEYSEAT 1 STANDARD KEYSEAT X NO KEYSEAT OR STANDARD KEYSEAT

Product Number Example → L09012 for L090 x 1/2 HUB

NOTE: L-JAW Hubs also available in aluminum – contact factory.

Standard Keyseat Dimensions

Shaft Dia.	Width	Depth
1/2 - 9/16	1/8	1/16
5/8 - 7/8	3/16	3/32
15/16 - 1-1/4	1/4	1/8
1-5/16 - 1-3/8	5/16	5/32
1-7/16 - 1-3/4	3/8	3/16
1-13/16 - 2-1/4	1/2	1/4
2-5/16 - 2-3/4	5/8	5/16
2-13/16 - 3-1/4	3/4	3/8
3-5/16 - 3-3/4	7/8	7/16
3-13/16 - 4-1/2	1	1/2
4-9/16 - 5-1/2	1-1/4	5/8
5-9/16 - 6-1/2	1-1/2	3/4

BORE TOLERANCES

BORE SIZE	TOLERANCE
UP TO AND INCLUDING 2"	+0.005 +0.015
OVER 2"	+0.005 +0.020

STOCK L-JAW METRIC BORE HUBS

BORE (MM)	PRODUCT NO.	L035	L050	L070	L075	L090	L095	L099	L100	L110	L150	L190	L225	L276
5	5	0												
6	6	1												
7	7		0											
8	8	0	0	0										
9	9													
10	10		X											
11	11		1		1									
12	12		1	1	1	1	1							
14	14		X	1	1	1	1	1	1					
15	15		1	1	1	1	1							
16	16			1	1	1	1		1					
17	17				1		1							
18	18				1	1	1		1	1				
19	19			1	1	1	1		1					
20	20				1	1	1	1	1	1	1			
22	22				1		1	1	1	1				
24	24					1	1	1	1	1				
25	25					1	1	1	1	1	1	1		
28	28						1	1	1	1				
30	30							1	1	1	1	1		
32	32								1	1	1		1	
35	35								1	1	1	1		
38	38									1	1	1	1	
40	40									1	1	1	1	
42	42									1	1	1	1	
45	45										1			
48	48										1	1		
50	50											1		
55	55													
60	60												1	
65	65												1	

C-JAW HUBS

BORE SIZE	PRODUCT NO.	C226	C276	C280	C285	C295	C2955
SOLID	S						
1/8	18						
3/16	316						
1/4	14						
5/16	516						
3/8	38						
7/16	716						
1/2	12						
9/16	916						
5/8	58						
11/16	1116						
3/4	34						
7/8	78	0	0				
15/16	1516						
1	1						
1 1/16	1116						
1 1/8	118						
1 3/16	1316						
1 1/4	114			X	X		
15/16	1516						
1 3/8	138	1					
1 7/16	1716						
1 1/2	112	1				0	
1 9/16	1916						
1 5/8	158	1					
1 11/16	11116						
1 3/4	134	1	1				0
1 7/8	178	1	1				
1 15/16	11516						
2	2	1	1				
2 1/8	218	1	1	1			
2 1/4	214						
2 3/8	238	1	1	1			1
2 1/2	212			1			
2 5/8	258		1	1			1
2 7/8	278						1
3	3						
3 3/8	338						
3 1/2	312						
3 5/8	358						
3 3/4	334						
3 7/8	378						

0 No Keyseat **1** Standard Keyseat **X** No Keyseat or Standard Keyseat

C-Jaw Product Number Example:

Item	Part No.	Description
Hub	C226212	C226x2 1/2
Cushion	C226N	Cushion Kit
Cover	C226CH	Cover Kit

BORE TOLERANCES

BORE SIZE	TOLERANCE
UP TO AND INCLUDING 2"	+ .0005 + .0015
OVER 2"	+ .0005 + .0020

Standard Keyseat Dimensions

Shaft Dia.	Width	Depth
1/2 - 9/16	1/8	1/16
5/8 - 7/8	3/16	3/32
15/16 - 1-1/4	1/4	1/8
1-5/16 - 1-3/8	5/16	5/32
1-7/16 - 1-3/4	3/8	3/16
1-13/16 - 2-1/4	1/2	1/4
2-5/16 - 2-3/4	5/8	5/16
2-13/16 - 3-1/4	3/4	3/8
3-5/16 - 3-3/4	7/8	7/16
3-13/16 - 4-1/2	1	1/2
4-9/16 - 5-1/2	1-1/4	5/8
5-9/16 - 6-1/2	1-1/2	3/4

L-JAW DIMENSIONS

Coupling Size	Hub Mat'l	DIMENSIONS					Weight Lbs*
		OD	HD	LTB	B	C	
L035	S.I.	0.63	0.63	0.27	0.81	0.28	0.10
L050	S.I.	1.08	1.08	0.63	1.72	0.47	0.30
L070	S.I.	1.36	1.36	0.75	2.00	0.50	0.60
L075	S.I.	1.75	1.75	0.81	2.13	0.50	1.00
L090	S.I.	2.11	2.11	0.81	2.13	0.50	1.50
L095	S.I.	2.11	2.11	1.00	2.50	0.50	1.80
L099	S.I.	2.53	2.53	1.06	2.88	0.75	2.50
L100	S.I.	2.53	2.53	1.38	3.50	0.75	3.50
L110	S.I.	3.33	3.33	1.69	4.23	0.85	6.60
L150	S.I.	3.75	3.75	1.75	4.50	1.00	9.10
L190	C.I.	4.50	4.00	1.94	4.88	1.00	17.00
L225	C.I.	5.00	4.25	2.19	5.38	1.00	23.00
L276	C.I.	6.19	5.00	3.13	7.88	1.63	47.00

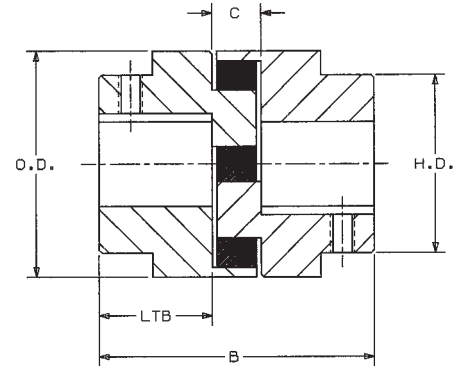

C-JAW DIMENSIONS

Coupling Size	Hub Mat'l	DIMENSIONS					Weight Lbs*
		OD	HD	LTB	B	C	
C226	C.I.	5.15	4.12	2.75	7.00	1.50	29.00
C276	C.I.	6.18	5.00	3.12	7.87	1.63	47.00
C280	C.I.	7.50	5.50	3.12	7.87	1.63	61.00
C285	C.I.	8.50	6.50	3.75	9.13	1.63	87.00
C295	C.I.	9.12	6.31	3.75	9.38	1.88	97.00
C2955	C.I.	9.12	7.12	4.25	10.38	1.88	117.00

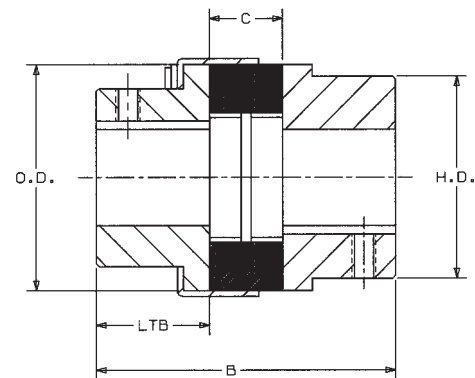

S.I. = Powdered metal • C.I. = Cast Iron

*Weight of coupling assembly with minimum bores.

NOTE: L-JAW Hubs also available in aluminum – contact factory.